

INEX SUCTION CABINET

FORTNA EQUIPMENT CO.
2985 S. Wyandot Street
Englewood, CO 80110
303-756-6066
www.fortnaequipment.com



Zero Products Division • One Cable Car Drive • Washington, MO 63090
Phone: 636/239-0300 • Fax: 636/239-0788 • www.clemcoindustries.com

NOTICE TO PURCHASERS AND USERS OF OUR PRODUCTS AND THIS INFORMATIONAL MATERIAL

The products described in this material, and the information relating to those products, is intended for knowledgeable, experienced users of abrasive blasting equipment.

No representation is intended or made as to the suitability of the products described herein for any particular purpose or application. No representations are intended or made as to the efficiency, production rate, or the useful life of the products described herein. Any estimate regarding production rates or production finishes are the responsibility of the user and must be derived solely from the user's experience and expertise, and must not be based on information in this material.

The products described in this material may be combined by the user in a variety of ways for purposes determined solely by the user. No representations are intended or made as to the suitability or engineering balance of the combination of products determined by the user in his selection, nor as to the compliance with regulations or standard practice of such combinations of components or products.

Abrasive Blast Equipment is only a component of the range of equipment used in an abrasive blasting job. Other products may include an air compressor, abrasive, scaffolding, hydraulic work platforms or booms, paint spray equipment, dehumidification equipment, air filters and receivers, lights, ventilation equipment, parts handling equipment, specialized respirators, or equipment that while offered by Clemco may have been supplied by others. Each manufacturer and supplier of the other products used in the abrasive blasting job must be contacted for information, training, instruction and warnings with regard to the proper and safe use of their equipment in the particular application for which the equipment is being used. The information provided by Clemco is intended to provide instruction only on Clemco products. All operators must be trained in the proper, safe, use of this equipment. It is the responsibility of the users to familiarize themselves with, and comply with, all appropriate laws, regulations, and safe practices that apply to the use of these products. Consult with your employer about training programs and materials that are available.

Our company is proud to provide a variety of products to the abrasive blasting industry, and we have confidence that the professionals in our industry will utilize their knowledge and expertise in the safe efficient use of these products.

OWNER'S MANUAL

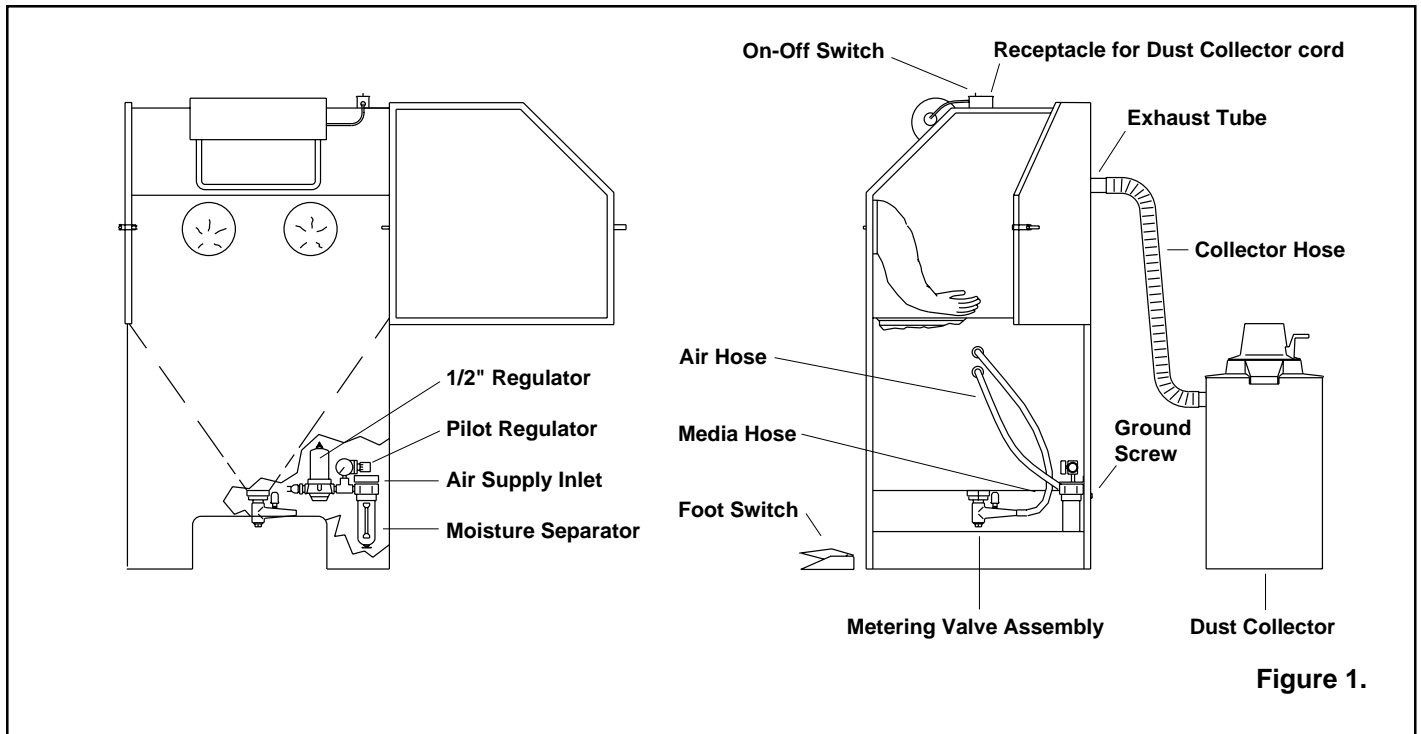

Figure 1.

1.0 INTRODUCTION

1.1 Scope: This manual covers set-up, operation and maintenance of the INEX Cabinet and dust collector.

1.2 General Description

1.2.1 The INEX Cabinet is an occasional-use, economy cabinet that utilizes the suction blast principle. Media is drawn into the blast gun's mixing body by the vacuum created by air moving through the gun assembly. This air/media mixture is propelled out the nozzle to strike against the part being blasted. After striking the object being blasted, the heavier, reusable media falls through into the hopper where it is recycled. The dust created by blasting is drawn out and collected in the dust collector. See figure 1 for general arrangement, and call-out of components.

1.3 Media

1.3.1 All common media 30-180 mesh specifically manufactured for abrasive blasting may be used in the INEX Cabinet. However, most types of sand are not recommended because their rapid breakdown rate creates excessive dust that may reduce the efficiency and the life of the dust collector. Aluminum oxide or silicon carbide may be used, but will accelerate wear on the cabinet, gun assembly, and hoses.

2.0 INSTALLATION

2.1 Location

2.1.1 Select a location where compressed air and electrical service are available. The location must comply with OSHA and local safety codes. Allow room for access to the doors and service areas and for handling of parts.

2.2 Air Supply

2.2.1 Compressor requirements depend on the size of air jet and the blasting pressure. See air jet/cfm chart in figure 2 to determine requirements. Unless ordered otherwise, cabinets are supplied with a no. 5 (5/32" orifice) jet.

BNP Gun	Jet	Nozzle	cfm	psi
No. 4	1/8"	5/16"	21.0	80
No. 5	5/32"	5/16"	31.9	80
No. 6	3/16"	3/8"	47.0	80

Figure 2.

2.2.2 Check the table in figure 3 to determine the minimum ID of air supply line.

Minimum Compressed Air Line ID			
Line Length	Jet Size No. 4	No. 5	No. 6
25'	3/4"	3/4"	1"
50'	3/4"	3/4"	1"
75'	3/4"	1"	1"
100'	3/4"	1"	1"

Figure 3.

2.2.3 Connect an air line from the air source to the moisture separator inlet, see figure 1. A shut-off valve should be installed at the source to enable lockout/tagout depressurization for service. If the cabinet is permanently installed, the air supply line should be hard piped.

⚠ WARNING

If twist-on type air hose couplings are used, they must be secured by safety wires to prevent injury from accidental disconnection under pressure.

2.3 Electrical Service

2.3.1 Connect a grounded wire to the copper ground screw on left rear of the cabinet.

⚠ CAUTION

To prevent injury from static shock, the cabinet must be grounded to prevent build-up of static electricity.

2.3.2 Remove the dust collector top assembly, by pushing down on both lid handles while pulling out on the flexible locking tabs located under each handle. Once the locking tabs have cleared the tabs on the collector drum, pull up on the top to remove. Check that the filter element is in place and free from obvious tears or other damage. Check that the diverter on the top assembly of the dust collector lines up with the inlet port on the drum. If not, the filter will wear prematurely. To replace the top assembly, align the tabs under the handles with the tabs on the drum. Press down on the handles to snap the top into place.

2.3.3 Make sure the cabinet power switch is turned off, then plug the collector power cord into the receptacle on the cabinet light switch assembly. Turn on the dust collector switch. The dust collector will be controlled by the light switch on the cabinet.

2.3.3 Plug the cabinet power cord into a 120 volt outlet.

⚠ WARNING

Do not use electrical adapters that eliminate the ground prong on the plug. Doing so can cause electric shock to the operator and also damage the equipment.

2.4 Connect the dust collector hose between the dust collector inlet and exhaust tube located on the outside rear of the cabinet. The ribbed end of the hose inserts into the opening of the dust collector. See Figure 1.

3.0 OPERATION

3.1 Media Loading/Unloading

3.1.1 Open one of the side doors and load the cabinet hopper no more than 1/4 full with media. **DO NOT LOAD THE HOPPER OVER 1/4 FULL OR EXCESS MEDIA MAY SWIRL ABOUT THE ENCLOSURE, REDUCING VISIBILITY AND INCREASING MEDIA CONSUMPTION.**

3.1.2 To drain spent or damp media, place an empty container under the metering valve, then unscrew the plastic plug from the valve.

3.2 Preparation before blasting

Read Section 4.1, before blasting.

3.2.1 Open the air supply line. Adjust pressure. See Section 4.1.

3.2.2 Turn on the control switch (mounted on top of the cabinet). The lights and exhaust motor should turn on. **NOTE:** The dust collector exhaust motor is supplied with a separate on/off switch. The dust collector must be on when blasting.

3.2.3 Load parts through either side door. Close and latch the door.

3.3 Start/Stop Blasting

⚠ WARNING

Read the blast media container for media-related hazards.

Avoid contact with and inhalation of dust.

Doors must be closed when the cabinet is in use.

Never blast without gloves.

Never blast toward view window.

After blasting, do not open the doors or turn off the power switch until the cabinet is cleared of airborne dust.

Do not blast if the cabinet or dust collector is leaking dust.

3.3.1 Firmly grip the BNP gun and point the nozzle toward the object to be blasted.

3.3.2 Step on the foot pedal. Blasting will begin almost immediately.

3.3.3 When blasting very small parts, place a screen over the grating to prevent parts from falling into the hopper. If an object falls through the grating, stop blasting and remove it immediately to prevent damage to the part or blockage of the metering valve or media line.

3.3.4 Avoid holding parts by hand that will require blasting into the glove.

3.3.5 To stop blasting, release the foot pedal.

4.0 ADJUSTMENTS

4.1 Blasting Pressure

4.1.1 The recommended maximum pressure for most cleaning applications is 80 psi. Some media types and applications will require lower pressure. Lower pressure may be used for delicate work. Optimum productivity is achieved when pressure is carefully monitored. The pressure regulator helps maintain proper blast pressure.

4.1.2 Adjust air pressure by turning the knob on the regulator, located on the inside of the cabinet skirt. Pull the knob out and turn clockwise to increase or counter-clockwise to decrease pressure. Once pressure is set, push the

knob in to lock. Operating pressure will usually drop from closed-line pressure when blasting is started.

4.2 Air Jet Adjustment

4.2.1 The air jet should be screwed 4-1/2 to 5 full turns into the rear of the BNP gun body. Doing so will leave 3-1/2 to 4 threads exposed past the lock nut. Tighten the lock nut to hold the jet in place.

4.3 Media/Air Mixture (Figure 4)

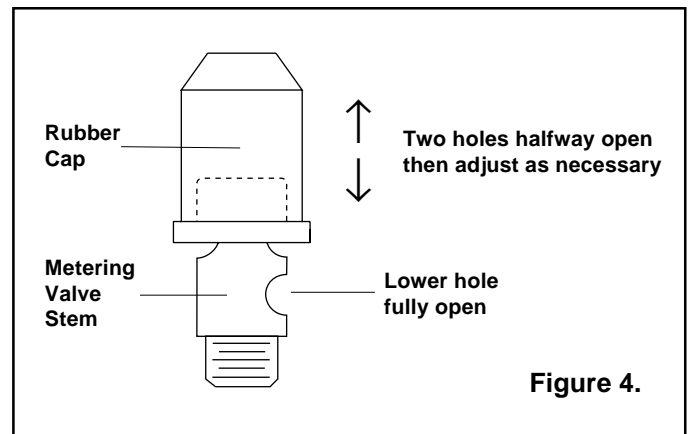

4.3.1 Begin blasting and check the media stream for correct mixture. Correct mixture appears as a light mist coming from the nozzle. Adjust the mixture by moving the rubber cap on the metering valve up or down.

4.3.2 As a starting point, the openings below the rubber cap on the metering valve stem should equal an area of two complete holes. EXAMPLE (see figure 4): The lower hole is completely open and the two upper holes are half open.

4.3.3 If the media hose seems to pulse, either the media has become damp and caked, or the air inlet on metering valve stem is out of adjustment. Check metering valve to see that one or more holes are open below the rubber cap.

4.3.4 If pulsation persists, increase air flow by moving the rubber cap up to uncover more of the holes.

4.3.5 If media flow is too light, decrease air in the mixture by moving the rubber cap down to cover more of the holes.

5.0 MAINTENANCE

NOTE: To prevent unscheduled downtime, establish a weekly inspection schedule. Inspect all parts subjected to media contact, including the gun, media hose, dust collector hose, plus all items covered in this section.

5.1 BNP Gun Assembly

5.1.1 Inspect the BNP gun for wear. Replacing the air jet cover before it wears through will prolong the life of the jet.

5.2 Dust Collector

WARNING

A dust respirator and eye protection must be worn when cleaning or replacing the filter. Service the filter only in a well-ventilated area.

5.2.1 Empty the dust collector drum, and clean the filter regularly. Start by checking it daily, then adjust frequency based on usage and breakdown rate of media.

5.2.2 Remove the top assembly by pushing down on both lid handles, while pulling out on the flexible locking tabs located under each handle. Once the locking tabs have cleared the tabs on the collector drum, pull up on the top to remove. **DO NOT LAY THE TOP ASSEMBLY ON THE FILTER.** Lay the top upside down on a clean surface while emptying the drum or changing the filter.

5.2.3 To remove the filter, unscrew the filter nut from the filter cage, then remove the filter plate and lift off the filter.

5.2.4 Clean the filter by gently tapping it against the inside wall of the drum, or by brushing the outside with a soft bristle brush.

5.2.5 Dump the contents of the drum into a suitable disposal container.

WARNING

Contact with or inhalation of some of the materials removed by blasting, such as red lead paint, may be harmful or fatal. Blasting media dust may also be harmful if inhaled. Wear an approved respirator when handling dust. Check with a local disposal company for disposal restrictions.

5.2.6 Inspect the filter. If it is worn or damaged, replace it.

5.2.7 Place the filter over the cage, being certain the

filter seats against flange on the cage.

5.2.8 Position the filter plate. Gently push the plate, to be certain the filter gasket seats into the channel of the plate.

5.2.9 Install the filter nut, with the lever facing away from

CAUTION

Do not over-tighten the filter nut as this will crack the plate or cage.

the plate. Tighten the nut finger tight only.

CAUTION

Be sure the diverter on the top assembly is lined up with the inlet port on the drum. If not, the filter will wear prematurely.

5.2.10 Place the top assembly onto the drum.

5.2.11 Align the tabs under the handles with the tabs on the drum. Press down on the handles to snap the top into place.

5.3 View Window Cover Lens

5.3.1 Install a cover lens on the inside surface of the window to prevent rapid frosting of the view window. Clean and dry the inside of the window. Remove the adhesive backing from the cover lens and apply the lens to the inside surface of the view window. When the cover lens becomes pitted, peel off and apply a new lens. **DO NOT BLAST TOWARD THE VIEW WINDOW.**

5.4 Moisture Separator

5.4.1 Cabinets work best with dry media. Therefore clean, dry compressed air is required. The cabinet is equipped with a moisture trap. It should be emptied daily, or more often if moisture is a problem, by opening the drain petcock. Be sure to completely close the petcock after draining.

5.5 Gloves

5.5.1 Special static-dissipating gloves protect the operator. Change the gloves as they wear. Deterioration may first be noticed as a static electricity "tickle" to the operator.

5.5.2 To replace the gloves, loosen the bands inside the cabinet with a screwdriver. Replace the gloves and tighten the bands.

5.6 Nozzle

5.6.1 Replace the nozzle when its diameter has increased by 1/16", or when suction diminishes noticeably. To change the nozzle, unscrew the holding nut from the gun end. Pull the nozzle from the gun and replace with a new nozzle, placing the tapered end toward the jet. Screw the holding nut back onto the gun.

5.7 Window Replacement (Figure 5)

5.7.1 Remove the old window by pulling the filler strip from the window molding. For the new window, push the window from the back to remove from the front.

WARNING

Use only approved laminated safety glass for replacement windows. Do not use plate glass. It can shatter and cause severe injury.

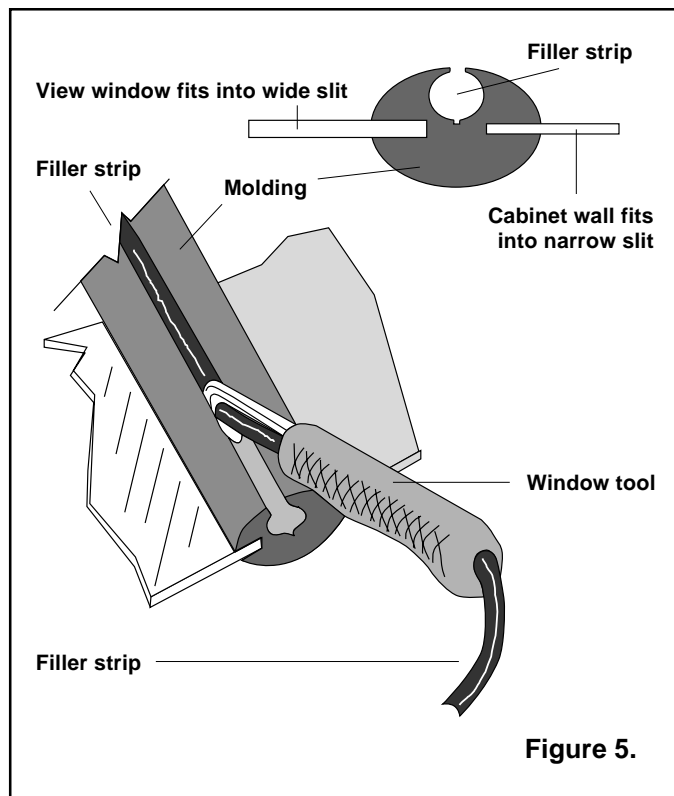

Figure 5.

5.7.2 Install the rubber window molding in the window opening by fitting the narrow slit of the molding over the metal edge of the opening. The filler strip channel must face the front of the cabinet. The molding ends should meet

in the middle of the straight section of the opening. Compress the rubber molding so the ends are tightly sealed.

5.7.3 From the front side, install the window into the wide slit of the molding.

5.7.4 Wipe the filler strip with a silicone lubricant to reduce friction. Thread the strip into the installation tool. This optional tool is listed in section 7.1.

5.7.5 Insert the end of the filler strip and installation tool into the filler strip channel of the molding. Feed the filler strip in while pulling the tool through the channel. **NOTE: START THE FILLER STRIP ON THE OPPOSITE SIDE OF THE MOLDING ENDS. FILLER STRIP AND MOLDING SHOULD END AT DIFFERENT LOCATIONS OR THE WINDOW MAY NOT SEAL PROPERLY.**

6.0 TROUBLESHOOTING

6.1 Poor Visibility

6.1.1 Exhaust motor switch turned off or cord not plugged into the cabinet outlet. The exhaust motor must operate before blasting begins.

6.1.2 Dirty filter. Clean the filter. Inspect for wear and replace if necessary.

6.1.3 Dust collector drum full. Empty dust container.

6.1.4 Using soft media that rapidly breaks down, or using media that is too fine or worn out. Replace media.

6.1.5 Cabinet intake filter blocked. Remove and clean the filter.

6.1.6 Hole worn in flexible hose. Replace hose and route it with as few bends as possible to prevent wear.

6.1.7 Dust collector top not seated correctly on dust drum. Check that gasket is in place and press top assembly firmly onto drum.

6.2 Reduced Cleaning Efficiency

6.2.1 Low media level. Check and fill.

6.2.2 Incorrect metering valve adjustment. See section 4.3.

6.2.3 Reduced air pressure. It may be caused by a malfunctioning regulator, a dirty filter in the moisture separator, ruptured or leaking air lines, or other air tools in use.

6.2.4 Worn gun parts such as nozzle or air jet. Replace all worn gun parts.

6.2.5 Worn media hose. Check for leaks or soft spots. Replace worn or damaged hose.

6.2.6 Air jet in gun out of adjustment. see section 4.2

6.3 Leaky Dust Collector

6.3.1 Damaged or loose filter. Replace filter and make sure diverter aligns with drum inlet.

6.4 Static Shocks

6.4.1 Cabinet and/or operator not grounded. Abrasive blasting creates static electricity. The cabinet must be grounded to prevent static buildup. If shocks persist, the operator may be building up static. Attach a small ground wire, such as a wrist strap (available at computer supply stores), from the operator to the cabinet.

6.5 Blockage in Media Hose

6.5.1 Media obstructions. Usually caused when the media mixture is too rich, adjust media /air mixture per section 4.3

6.5.2 Wet or damp media, see section 6.6.

6.6 Media Clotting

6.6.1 Excessive moisture. If media clots and jams the metering valve, there is probably moisture in the system. This may caused by an overheating compressor that pumps oil into the air line or by air lines that are too long, allowing moisture to condense on the inside. Drain the moisture separator and receiver tank frequently. If the problem continues, it may be necessary to change the media in the hopper daily, especially if fine mesh media is used. Some types of media absorb moisture from the air when left in the hopper overnight. If the problem persists, install an air dryer.

6.7 Media Surging

6.7.1 Rich media mixture. Increase air flow. See section 4.3.

6.8 Poor Suction In Media Hose

6.8.1 Inadequate air supply. Check the charts in Figures 3 and 4.

6.8.2 Air jet out of adjustment. See section 4.2.

6.8.3 Worn nozzle. Replace if worn 1/16" or more.

6.8.4 Blockage in media hose or nozzle. See section 6.5.

6.8.5 Wrong jet/nozzle combination. See chart, Figure 2.

6.8.6 Air jet sleeve extends past end of air jet. Cut the sleeve to align with the air jet.

6.9 Blow-Back Through Media Hose

6.9.1 Blockage in nozzle. Remove nozzle and clear blockage.

6.9.2 Air jet too large for nozzle. See chart, Figure 2.

7.0 REPLACEMENT PARTS

7.1 Cabinet Assembly (Figure 6)

Item	Description	Stock No.
(-)	INEX Model 3036, complete	14424
(-)	INEX Model 3048, complete	14425
(-)	Installation Tool, window	12176
1.	Glove, set	11215
2.	Glove, left hand	12710
3.	Glove, right hand	12711
4.	Glove clamp, each	11576
5.	View window	12212
6.	Window molding with filler strip	14407
7.	Cover lens, window, Pkg. of 5	06190
8.	Grommet, media/air hose (2)	11798
9.	Exhaust tube, 2"	20310
10.	Latch assembly, door	10908
11.	Gasket, door, (10 ft. required for each door)	12434
12.	Grate for 3036	10759
	Grate for 3048	10761
13.	Light shield assembly	10767
14.	Light fixture	12716
15.	U-Channel extrusion	06179
16.	Fluorescent lamp	11362
17.	Adapter base, lamp	11363
18.	Cover plate, receptacle	10787
19.	Control switch/receptacle	10769
20.	Electric cord w/ plug	11669
21.	Filter, air inlet	14047
22.	Moisture separator, 1/2"	01308
23.	Bracket, moisture separator	11552
24.	Pressure regulator, 1/2" pilot operated ...	11345
25.	Regulator, 1/8" pilot	12715
26.	Gauge, pressure	01908
27.	Screw, 1/4nc x 3/4, brass	03132
28.	Nut, 1/4nc brass jam	03133

Item	Description	Stock No.
29.	Hose, 1/2" air, 6 ft. required	12472
30.	Hose, media, urethane, 6 ft. required	12476
31.	Metering valve, complete	12417
32.	Foot pedal, complete	20483

Item	Description	Stock No.
33.	Clamp, 2-1/2" hose	02817
34.	Hose, dust collector	20101
35.	Dust collector, complete, includes hose ..	20081
36.	Holder, light fixture	13112

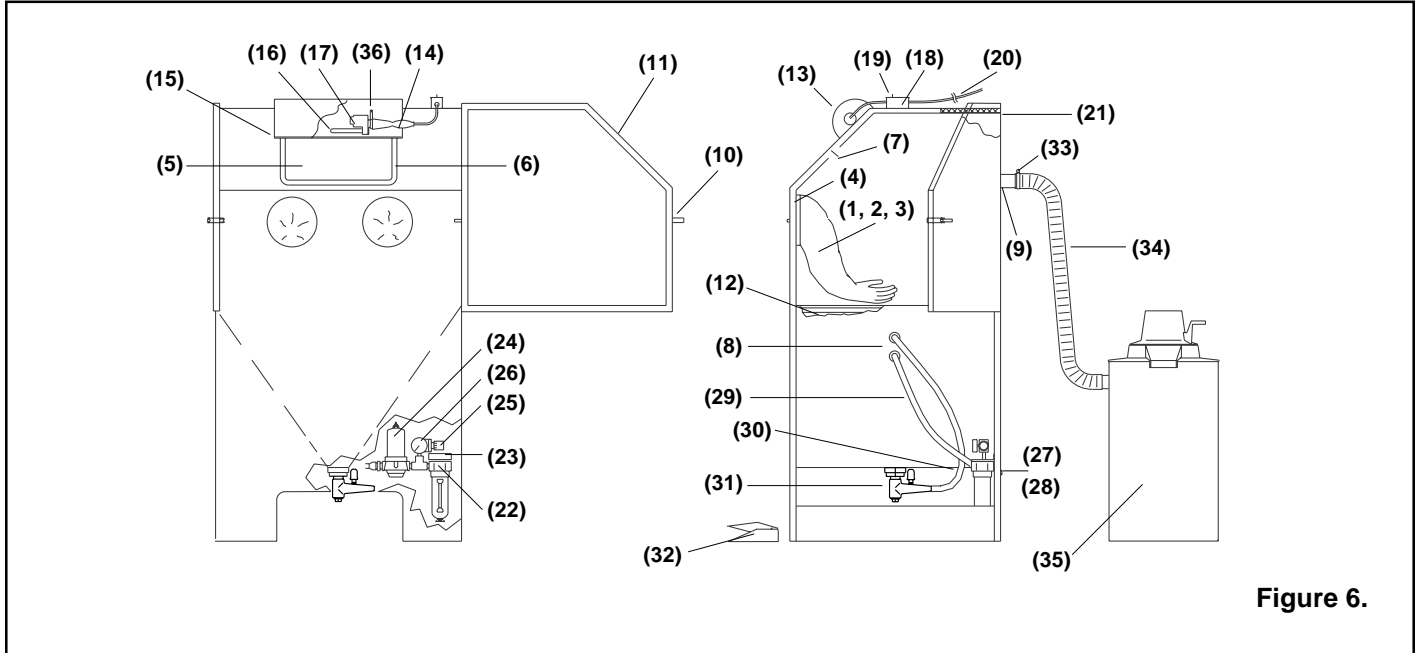

Figure 6.

7.2 Dust Collector
(Figure 7)

Item	Description	Stock No.
(-)	Dust collector w/hose assembly	20081
1.	Filter, dust collector	20098
2.	Hose, dust collector	20101
3.	Screw, 10 x 3/4	03912
4.	Gasket, U-channel, 4 ft. required	06179
5.	Motor cover	20088
6.	Lid panel, top	20089
7.	Gasket, motor	20090
8.	Switch	20091
9.	Motor assembly	20092
10.	Blower wheel	20093
11.	Lid panel, bottom	20094
12.	Nut, blower wheel	20095
13.	Deflector	20096
14.	Cage, filter	20097
15.	Plate, filter	20099
16.	Nut, filter	20100

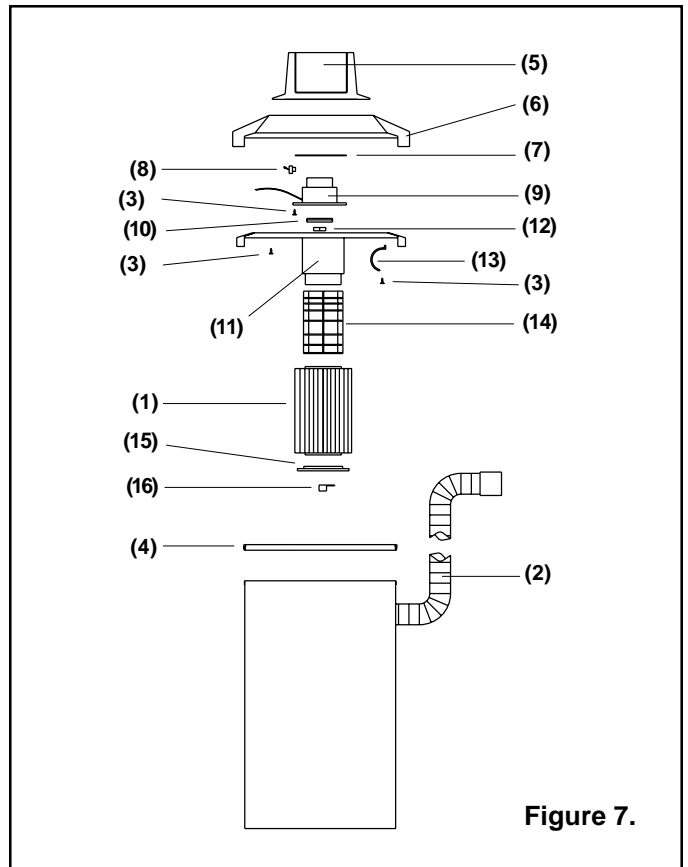

Figure 7.

7.3 BNP Gun and Feed Assembly
(Figure 8)

Item	Description	Stock No.
1.	BNP Gun assemblies, (less nozzle and hose assemblies)	
	No. 4 Gun	12301
	No. 5 Gun	12302
	No. 6 Gun	12303
2.	Nut, nozzle holding	11914
3.	Nozzle, Ceramic	
	No. 5	11930
	No. 6	11931
	Nozzle, Boron Carbide	
	No. 5	11935
	No. 6	11936
	Nozzle, Tungsten Carbide	
	No. 5	13118
4.	O-Ring	08975
5.	Gun body	11802
6.	Lock nut, air jet	11913
7.	Rubber sleeve	12097
8.	Air jet assembly, (includes item 7)	
	No.4	12342
	No.5	12343
	No.6	12344
9.	Hose end, 1/2" barb x 1/2" female swivel.	15002
10.	Fitting, 1/2" npt x 1/2" flare	11351

11.	Hose, 1/2" air, 6 ft. required	04905
12.	Hose, 5/8" media, 6 ft. required	04906
13.	Metering valve, complete	12417
14.	Cap, metering valve	12012
15.	Stem, metering valve	12148
16.	Body, metering valve	11532
17.	Plug, metering valve	2011
18.	Fitting, hose, 3/8" npt x 1/2" barb	06369
19.	Foot pedal, complete	20483
20.	Tubing, urethane twinline, 4 ft. required ...	19577
21.	Bushing, 1/4" x 1/8"	02010
22.	Fitting, tube, 1/8" npt x 1/8" barb	11732
23.	Top pedal	20017
24.	Pedal bottom	20148
25.	Air valve, n/c	20026
26.	Drive pin, grooved	20109
27.	Screw, socket head, 1/4 nf x 3/4"	03086
28.	Screw, fh, 10-32 x 1/2"	19571
29.	Fitting, tube, 10-32 pipe x 1/8" barb	11731
30.	Spring, 1-1/4" O.D. x 3-1/2"	20121
31.	Gauge, pressure	01908
32.	Regulator, 1/8" pilot	12715
33.	Tee, 1/2" npt	01787
34.	Nipple, 1/2" close	01733
35.	Bushing, 1/2" x 1/8" npt	11350
36.	Connector, 1/8" brass	01962
37.	Moisture separator	01308
38.	Pressure regulator, 1/2" pilot operated ...	11345

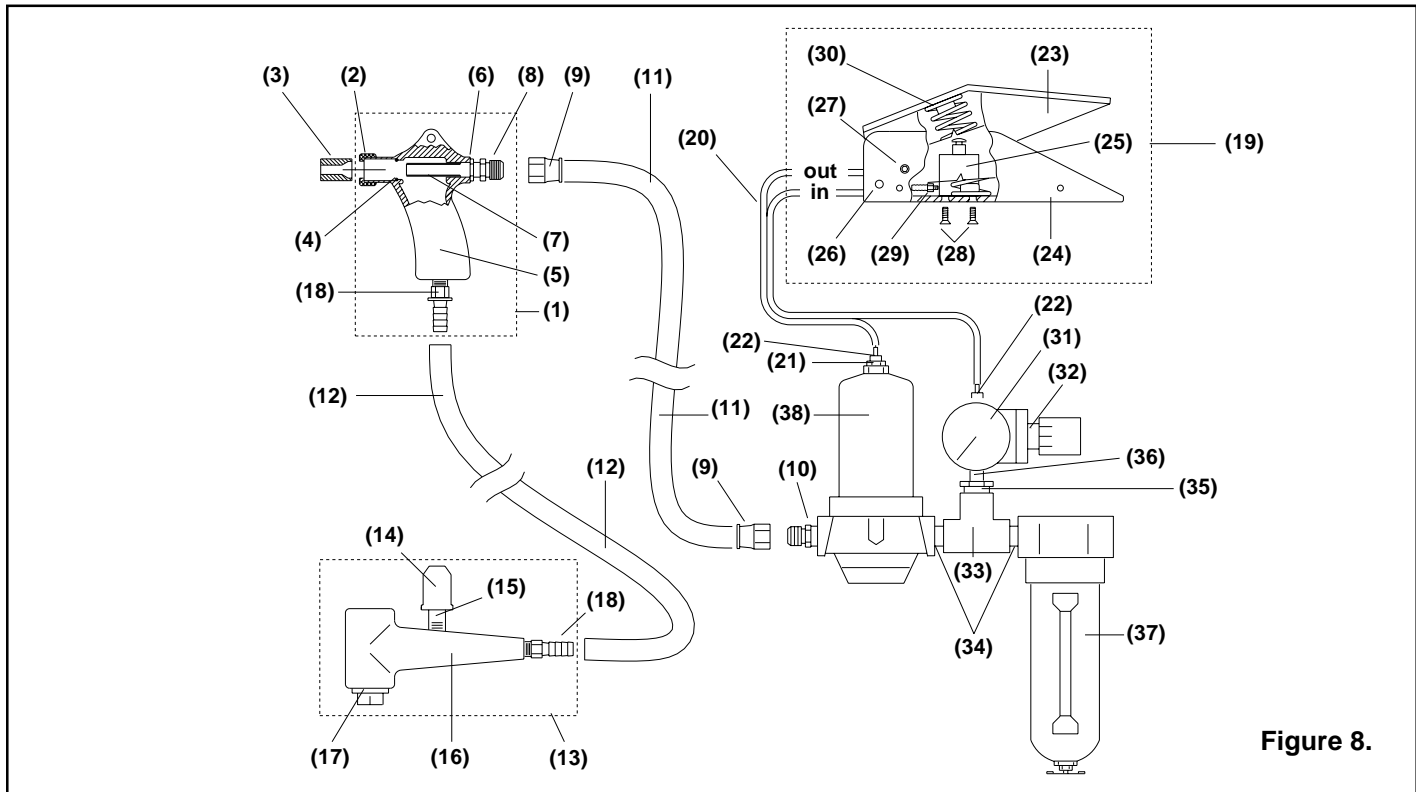

Figure 8.