

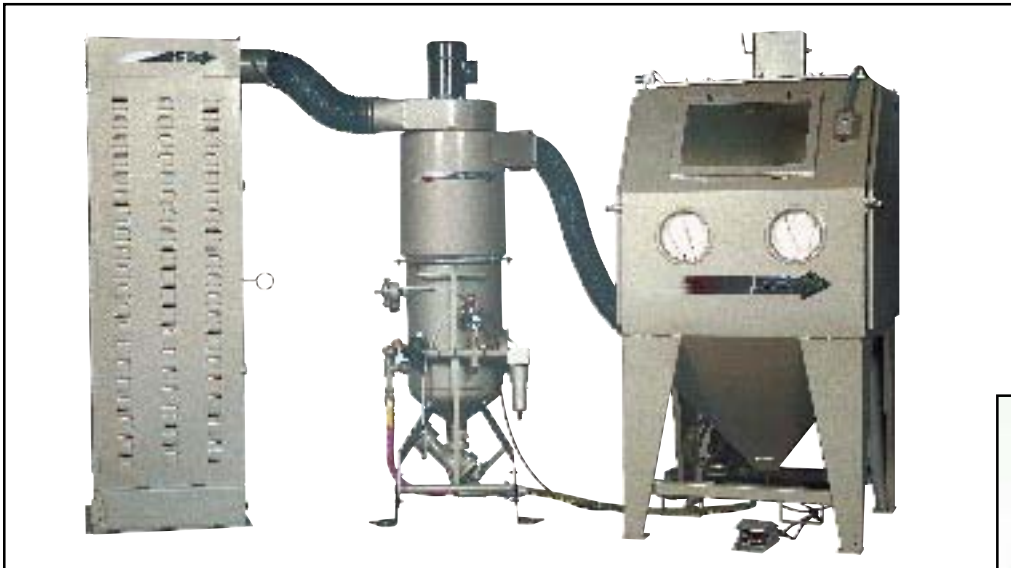

# BNP 65 Pressure Blast Cabinet

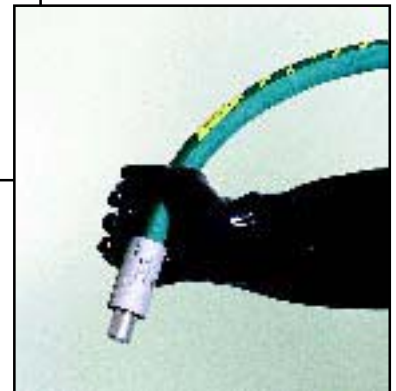

**Clean  
Peen  
Deburr  
Finish**



Model BNP 65P-600 DF

*For tough cleaning jobs, pressure blasting delivers higher abrasive velocity for greater impact intensity, compared to suction blasting, and can increase your production rate by as much as 300 percent.*

## Common Applications

- Remove rust, mill scale, heat scale, and carbon buildup from metals
- Strip paint, powder coating, plating, and anodizing from parts for rework
- Eliminate burrs, parting lines, flashings, and other defects from castings and injection-molded parts
- Extract residual sand from castings
- Beautify steel, stainless steel, aluminum, brass and other metals with a uniform matte finish
- Etch artwork and lettering into glass, stone, plastics, metal and other materials
- Clean release agents and material buildup from molds

## BNP 65 Pressure Cabinets Feature: Safety

- ✓ Full-length, neoprene-on-fabric gloves resist wear and protect operator.
- ✓ Ceiling-mounted, two-tube fluorescent light fixture with abrasive resistant Lexan® cover for extraordinary visibility.
- ✓ Safety interlocks interrupt blasting if either door is opened. (Conforms to US regulations.)
- ✓ Adjustable, heavy-duty chromed latches seal doors tight through years of service.

## Productivity

- ✓ High efficiency, 2.0 cubic foot capacity, ASME-coded pressure vessel, fitted with 1" ID piping, industrial-quality blast hose and couplings and cabinet integrated controls.
- ✓ Unique Air Logic system (pilot actuated) to maximize air flow to the nozzle.
- ✓ Double-wall, sound-insulated doors, with industrial-quality lift-off hinges.
- ✓ 14-gauge steel all-welded construction, with precisely formed bends, forms a rigid, long-lasting cabinet shell.

## Convenience

- ✓ Tilt-out window, for tool-free glass changes in minutes.
- ✓ Pressure regulator, gauge, and electric switch mounted within easy reach.
- ✓ Built-in blow-off gun helps keep dust inside the cabinet, not on your floor.

## Tungsten Carbide Blast Nozzle

The standard No 3 tungsten carbide nozzle is perfect for most blasting, while the optional boron carbide nozzles stand up to hundreds of hours of blasting with aluminum oxide or other aggressive abrasives. The cabinet's blast and recovery systems can support up to a No 6 (3/8-inch) nozzles

## Popular Accessories

- Adjustable Gun Mpoint
- Adjustable Vortex Tube (for lightweight media)
- Air-powered Vertical Lift Door
- Alox Kit
- Curtains ( black or high visibility white)
- HEPA filter (RP model only)
- Manometer Kit
- Oscillator Assembly
- Timed door release
- 20" and 24" Dia. Turntables
- Work Car & Track Assembly

# S P E C I F I C A T I O N S

## COMPLETE SYSTEM

Actual space required depends on equipment configurations, options and desired work flow. Allow additional work space for operator and maintenance access.

- A. 36.5" deep
- B. 42" wide
- C. 79" high

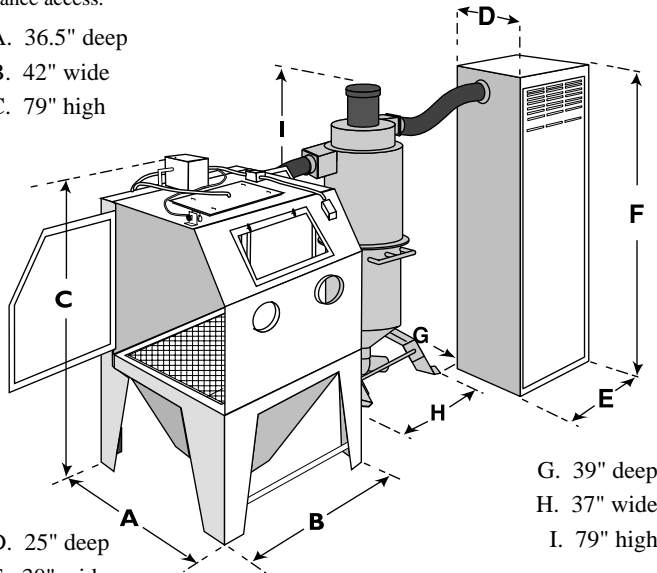

- D. 25" deep
- E. 30" wide
- F. 79.5" high

- G. 39" deep
- H. 37" wide
- I. 79" high

Model illustrated: BNP 65P-600 DF  
600 CFM Reclaimer and Dry Filter

## CABINET

### Working Chamber Size

36" wide (914 mm)  
35" deep (889 mm)  
37" high (940 mm)

### Door Opening

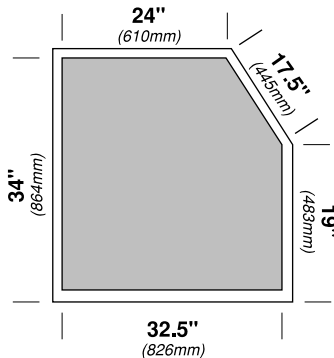

### Window Size (safety glass)

19.5" wide (495 mm)  
12.5" high (317 mm)

Door interlock system conforms to U.S. government regulations

## DUST COLLECTORS

Dry filters are suitable for most industrial applications where the dust collector can be shut off periodically to shake dust from the 100% cotton sateen filter tubes. Dry filters trap 98% of dust down to 1.0 micron.

Reverse pulse cartridge dust collectors (which trap 99.7% of dust down to 0.5 micron) allow non-stop, high-production blasting. The polyester-cellulose cartridges are automatically pulse cleaned for maximum filter efficiency. Worn cartridges can be replaced in minutes.

Dry Filters	Reverse Pulse Collector
5 sq ft filter area per tube 300 cfm DF has 15 tubes (75 sq ft) 600 cfm DF has 25 tubes (125 sq ft)	235 sq ft filter area per cartridge RPC-2 has two cartridges (470 sq ft)

Clemco is committed to continuous product improvement. Specifications are subject to change without notice.

Clemco Industries is an ISO 9001 certified company.

## BLAST/RECLAIM SYSTEM

### The Heart of ZERO's Blasting System

Our exclusive media reclaimers continuously extract dust and debris and return properly sized, usable media to the blast system. The standard reclaimer handles all non-metallic media. For metallic media, specify reduced ID conveying hose.

The versatile design of our 600-cfm and larger reclaimers lets you quickly adapt the system to your changing needs - add media hoppers, rubber liners, or pull-through dust-collection.

The reclaimer, mounted atop the pressure vessel, automatically refills the blast system with clean, recycled media.

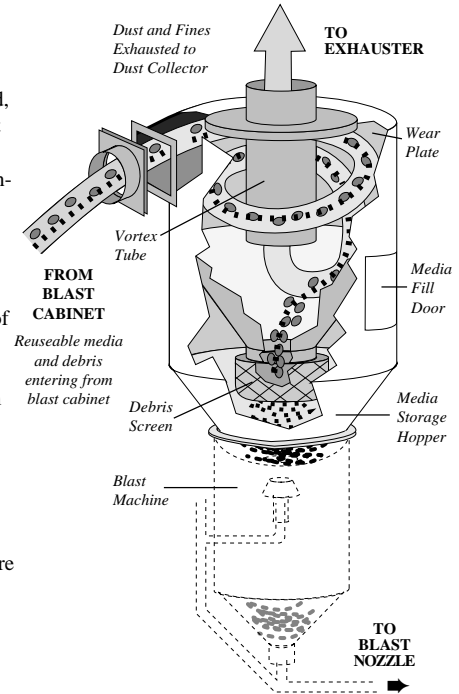

## NOZZLES

### AIR REQUIREMENTS

NOZZLE	NOZZLE ORIFICE	CFM at 80 PSI	M <sup>3</sup> /Min at 5,5 BAR	CFM at 100 PSI	M <sup>3</sup> /Min at 7 BAR
No. 3	3/16"	38	1,08	45	1,3
No. 4	1/4"	68	1,93	81	2,3
No. 5	5/16"	113	3,20	137	4,0
No. 6	3/8"	161	4,56	196	5,6

BNP-65 cabinets are furnished with a No. 3 tungsten carbide nozzle.

## ELECTRICAL

600 CFM (17 m<sup>3</sup>/m) 1HP, 115V, 1PH, 60HZ, (.75KW, 220V, 1PH, 50HZ); available with either single phase or three phase motors.

900 CFM (25 m<sup>3</sup>/m) 2HP, 220V, 3PH, 60HZ, (1.5KW, 220V, 3PH, 50HZ); available with three phase motors only.

For three phase motors, specify 230v or 460v.

Other motors and electrical configurations are available to make your system compatible with local power systems.

## ORDERING INFORMATION

Model Number	Reclaim CFM (m <sup>3</sup> /m)	Dust Collection	Single Phase	Three Phase	Ship Wt. lb(kg)
BNP-65P-600 DF	600 (17)	Dry Filter	19967		1,140 (517)
BNP-65P-600 RPC	600 (17)	RPC-2	19968		1,525 (692)
BNP-65PM-900 DF	900 (25)	Dry Filter		22337	1,290 (585)

Distributed By:

**FORTNA EQUIPMENT CO.**  
2985 S. Wyandot Street  
Englewood, CO 80110  
303-756-6066  
[www.fortnaequipment.com](http://www.fortnaequipment.com)