



BNP 220 Suction Blast Cabinet



Model BNP-220-600 DF

**Clean
Peen
Deburr
Finish**

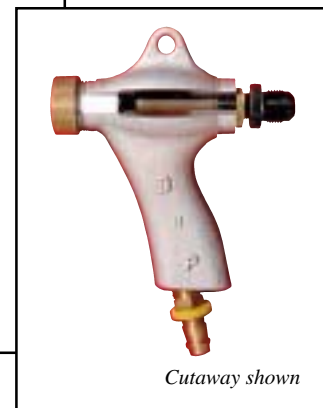

Cutaway shown

BNP blast cabinets deliver efficient, affordable media blasting to clean,peen, deburr, or finish parts.

Common Applications

- Remove rust, mill scale, heat scale, and carbon buildup from metals
- Strip paint, powder coating, plating, and anodizing from parts for rework
- Eliminate burrs, parting lines, flashings, and other defects from castings and injection-molded parts
- Extract residual sand from castings
- Beautify steel, stainless steel, aluminum, brass and other metals with a uniform matte finish
- Etch artwork and lettering into glass, stone, plastics, metal and other materials
- Clean release agents and material buildup from molds

BNP 220 Cabinets Feature:

Safety

- ✓ Full-length, neoprene-on-fabric gloves resist wear and protect operator.
- ✓ Ceiling-mounted, two-tube fluorescent light fixture with abrasive resistant Lexan® cover for extraordinary visibility.
- ✓ Safety interlocks interrupt blasting if either door is opened. (Conforms to US regulations.)
- ✓ Adjustable, heavy-duty chromed latches seal doors tight through years of service.

Productivity

- ✓ Unique Air Logic system (pilot actuated) to maximize air flow to the blast gun.
- ✓ Double-wall, sound-insulated doors, with industrial-quality lift-off hinges.
- ✓ 14-gauge steel all-welded construction, with precisely formed bends, forms a rigid, long-lasting cabinet shell.

Convenience

- ✓ Tilt-out window, for tool-free glass changes in minutes.
- ✓ Pressure regulator, gauge, and electric switch mounted within easy reach.
- ✓ Built-in blow-off gun helps keep dust inside the cabinet, not on your floor.

BNP Blast Gun with Ceramic Nozzle

The BNP blast gun sets the industry standards for performance, versatility, and durability. The ergonomically proven grip reduces operator fatigue and increases productivity. The standard ceramic nozzle is perfect for bead blasting, while the optional tungsten or boron carbide nozzles stand up to hundreds of hours of blasting with today's aggressive abrasives.

Popular Accessories

- Adjustable Gun Mount
- Adjustable Vortex Tube (for lightweight media)
- Alox Kit
- Air-powered Vertical Lift Door
- Curtains (black or high visibility white)
- HEPA filter (RP model only)
- Manometer Kit
- Oscillator Assembly
- 20", 24" & 30" Dia. Turntables
- Work Car & Track Assembly
- Two Gallon Tumble Basket
- Timed Door Release
- A-300 Automation Kit

S P E C I F I C A T I O N S

COMPLETE SYSTEM

Actual Space required depends on equipment configurations, options and desired work flow. Allow additional work space for operator and maintenance access.

- A. 88" deep (includes free-standing reclaimer)
- B. 56" wide
- C. 83.5" high

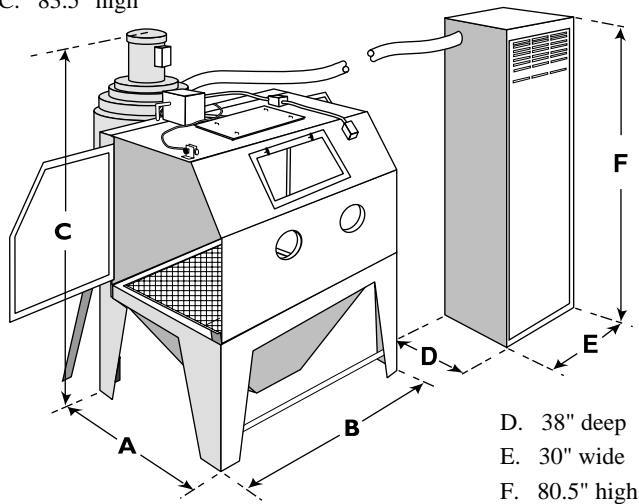

- D. 38" deep
- E. 30" wide
- F. 80.5" high

Model illustrated: BNP-220-900 DF
900 CFM Reclaimer (free standing) and Dry Filter

CABINET

Working Chamber Size

50" wide (1270 mm)
39" deep (991 mm)
43" high (1092 mm)

Window Size (safety glass)

19.5" wide (495 mm)
12.5" high (318 mm)

Door Opening

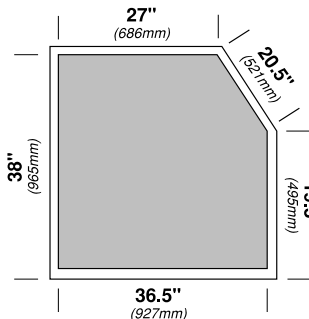

Door interlock system conforms to U.S. government regulations.

DUST COLLECTORS

Dry filters are suitable for most industrial applications where the dust collector can be shut off periodically to shake dust from the 100% cotton sateen filter tubes. Dry filters trap 98% of dust down to 1.0 micron.

Reverse pulse cartridge dust collectors (which trap 99.7% of dust down to 0.5 micron) allow non-stop, high-production blasting. The polyester-cellulose cartridges are automatically pulse cleaned for maximum filter efficiency. Worn cartridges can be replaced in minutes.

Dry Filters	Reverse Pulse Collector
5 sq ft filter area per tube 600 cfm DF 25 has tubes (125 sq ft) 900 cfm DF has 40 tubes (200 sq ft)	235 sq ft filter area per cartridge RPC-2 has two cartridges (470 sq ft)

Clemco is committed to continuous product improvement. Specifications are subject to change without notice.
Clemco Industries is an ISO 9001 certified company.

MEDIA RECLAIMERS

The Heart of ZERO's Blasting System

Our exclusive media reclaimers continuously extract dust and debris and return properly sized, usable media to the blast system. The standard reclaimer handles all non-metallic media. For metallic media, specify reduced ID conveying hose.

The suction blast metering valve is infinitely adjustable from fully-closed to wide open, and locks into any setting without tools.

The versatile design of our 600-cfm and larger reclaimers lets you quickly adapt the system to your changing needs—add media hoppers, a pressure blast system, or pull-through dust collection.

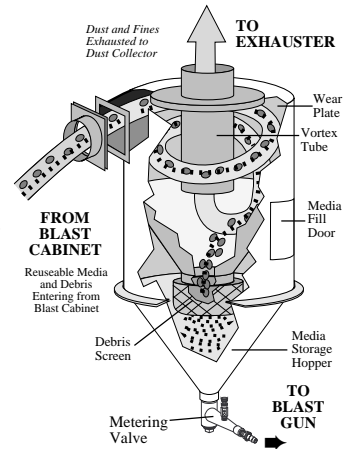

BNP BLAST GUN

AIR CONSUMPTION

SIZE	NOZZLE ORIFICE	AIR JET	CFM at 80 PSI	M ³ /Min at 5,5 BAR	MINIMUM RECLAIMER
No. 4	1/4"	1/8"	21	0,60	300 CFM (8,5 m ³ /m)
No. 5	5/16"	5/32"	32	0,90	300 CFM (8,5 m ³ /m)
No. 6	3/8"	3/16"	48	1,35	600 CFM (17 m ³ /m)
No. 7	7/16"	7/32"	62	1,76	600 CFM (17 m ³ /m)
No. 8	1/2"	1/4"	85	2,41	600 CFM (17 m ³ /m)

BNP 220 suction cabinets are furnished with a No. 5 ceramic nozzle.

ELECTRICAL

600 CFM (17 m³/m) 1HP, 115V, 1PH, 60HZ, (.75KW, 220V, 1PH, 50HZ); available with either single phase or three phase motors.

900 CFM (25 m³/m) 2HP, 220V, 3PH, 60HZ, (1.5KW, 220V, 3PH, 50HZ); available with three phase motors only.

For three phase motors, specify 230v or 460v.

Other motors and electrical configurations are available to make your system compatible with local power systems.

ORDERING INFORMATION

Model Number	Reclaim CFM (m ³ /m)	Dust Collection	Single Phase	Three Phase	Ship Wt. lb(kg)
BNP-220-600 DF	600 (17)	Dry Filter	19955	19956	1,025 (465)
BNP-220-600 RPC	600 (17)	RPC-2	19958	19960	1,295 (588)
BNP-220M-900 DF	900 (25)	Dry Filter		22338	1,155 (525)
BNP-220-900 DF	900 (25)	Dry Filter		19962	1,155 (525)
BNP-220-900 RPC	900 (25)	RPC-2		19964	1,435 (652)
BNP-220-900 RPH	900 (25)	RPC-2		19965	2,010 (912)

Distributed By:

FORTNA EQUIPMENT CO.
2985 S. Wyandot Street
Englewood, CO 80110
303-756-6066
www.fortnaequipment.com